

Influence of silane coupling agents on interlaminar fracture in glass fibre fabric reinforced unsaturated polyester laminates

Y. SUZUKI*, Z. MAEKAWA, H. HAMADA, A. YOKOYAMA, T. SUGIHARA
Faculty of Textile Science, Kyoto Institute of Technology Matsugasaki, Sakyo, Kyoto 606, Japan

M. HOJO

Mesoscopic Materials Research Center, Kyoto University, Sakyo, Kyoto 606 01, Japan

The relationship between the adhesive properties of the interphase of glass fibre/resin and the resultant composite Mode I delamination fracture toughness in glass fibre fabric laminate (GFFL) was studied. The Mode I interlaminar fracture toughness of GFFL was obtained by using a double cantilever beam (DCB) specimen. The delamination resistance of GFFLs which have two silane coupling agents and three concentration finishes is discussed on the basis of interlaminar fracture toughness. The crack propagation behaviour of DCB testing was mainly divided into stable and unstable manners. The fracture toughness and the crack propagation behaviour were dependent on the types and concentration of silane coupling agents.

1. Introduction

Glass fibre fabrics are used as materials of reinforcement and electrical insulation for printed circuit boards. An increase in the density of patterns for printed circuit boards is, however, required in the electronics industry, and increasingly the very important properties, such as heat resistance, dimensional stability and resin impregnation, need to be improved. The heat resistance is the most important property which is currently the limiting factor in many design applications. Silane coupling agents are widely used as finishing agents for glass fibre fabrics of glass fibre/matrix composites in order to obtain a good heat resistance of the printed circuit boards. However, a silane coupling agent is an adhesive material which acts like a bridge between the glass fibre and the matrix, and the heat resistance of laminate is thus greatly influenced by the silane coupling agents [1].

The "pressure cooker test" [1, 2], which is a typical industrial test for heat resistance, is often used in our laboratory to evaluate the performance of printed circuit boards. This test is valuable in predicting whether laminates can withstand introduced humidity during the manufacturing process of printed circuit boards. Penetration of water into the interfacial region (glass fibre/matrix) can be accelerated by boiling coupons in a pressure cooker and is then observed by immersing the boiled coupons in molten solder. Because the heat of the molten solder suddenly converts water into steam, it can be observed visually that delamination occurs. From this test, we can estimate roughly the heat resistance of the glass fibre fabric

laminates. However, measurements which can give a numerical value for the delamination resistance have not yet been developed.

The mechanical property and heat resistance of GFFL composite are influenced by the adhesive property of the glass fibre/matrix interphase. Crick *et al.* [3] suggests that the interlaminar fracture morphology of carbon fibre/PEEK interphase can be examined using the Mode I interlaminar fracture toughness test. Because the crack propagation behaviour of the double cantilever beam (DCB) test is similar to the growth of the delamination of the GFFL in the pressure cooker test, fracture toughness values can be used as a simulation for the delamination. The observation of crack propagation during DCB tests is also important to evaluate the delamination resistance.

The goal of this research was to understand the relationship between the adhesive properties of glass fibre/matrix interphase and the resultant Mode I interlaminar fracture toughness. Mode I interlaminar fracture toughness of glass fibre fabric laminates which were finished using two silane coupling agents under three concentrations was measured.

2. Experimental procedure

2.1. Materials and specimens

The vinylester resin (Ripoxy R-806B) of unsaturated polyester resin for the matrix was polymerized with 0.7 wt % methyl-ethyl-ketone-peroxide. The plain E-glass fibre fabric was WE18W 44(warp) × 34(weft) strand count/inch. The fibre strand from the E-glass

Present address: Nitto Boseki Co., Ltd, 20 Ipponsugi, Sakurashimo, Fukushima 960-21, Japan.

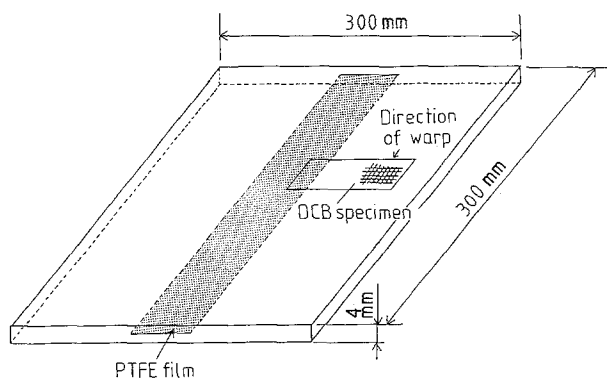

Figure 1 Schematic diagram of the glass fibre fabric laminate for DCB specimen.

fibre fabric consisted of four hundred glass fibre filaments (9 μm diameter). Both γ -methacryloxypropyltrimethoxysilane: A-174 (methacryl silane) and γ -glycidoxypropyltrimethoxysilane: A-187 (epoxy silane) were used as silane coupling agents. Methacryl silane has an organic function which can react with the double bond of vinyl ester resin. On the other hand, epoxy silane has no double bond in its molecular structure. The aqueous solutions of silane coupling agents were acidified with acetic acid at pH 4.0. Glass fibre fabrics were dipped into the aqueous solutions of 0.01, 0.4, 1.0 wt % methacryl silane and 0.4 wt % epoxy silane, and then squeezed with squeeze rolls and dried at 110°C for 10 min.

Fig. 1 shows a schematic diagram of glass fibre fabric laminate for DCB specimens. These laminate materials were cured for 48 h at room temperature. Twenty-ply laminates were fabricated by a hand lay-up technique for DCB testing. Each laminate material volume fraction was about 44%. A PTFE 40 μm thick film was inserted on the midplane as a starter slit during fabrication, as shown in Fig. 1. The laminate materials were cut into pieces approximately 100 mm long, 25 mm wide and 4 mm thick. The longitudinal direction of the pieces was parallel to the weft glass fibre strand, as shown in Fig. 1.

2.2. Fracture toughness test

Fig. 2 shows the DCB specimen geometry and testing apparatus. The specimens were loaded at a crosshead rate of 1.0 mm min⁻¹ using an Instron 4206. The crack propagation length was obtained from the mean value of the crack length on both sides of the specimen by using two travelling microscopes. The specimens were loaded continuously to obtain a 10 mm increment of crack length and then the specimens were unloaded. This procedure was continued until the specimens were split into two parts.

2.3. Data analysis of interlaminar fracture toughness

G_I was calculated from

$$G_I = \left(\frac{P^2}{2B} \right) \left(\frac{d\lambda}{da} \right) \quad (1)$$

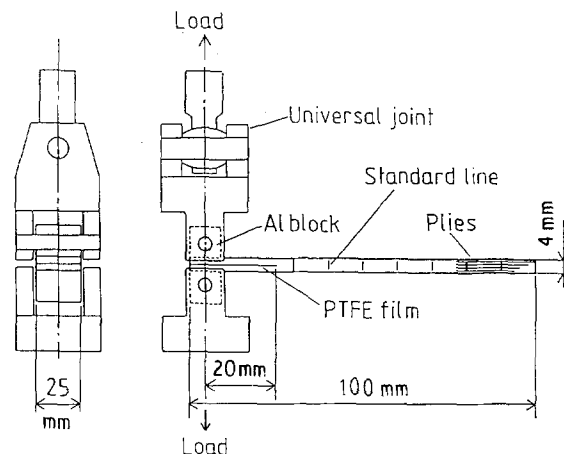

Figure 2 DCB specimen and testing apparatus.

where P is the load, B the specimen width, a the crack length, and λ the compliance. The value of the interlaminar fracture toughness, G_I , was calculated using Kageyama's analytical compliance method [4]

$$a/H = A_1 \lambda^{1/3} + A_0 \quad (2)$$

where H is the half length of the specimen thickness. The slope of the line is A_1 and the value of G_I is then determined from

$$G_I = \frac{3P_c^2 \lambda^{2/3}}{2A_1 B H} \quad (3)$$

where P_c is the critical load.

Fig. 3 illustrates the relation between the normalized crack length and the compliance of 0.4 wt % epoxy silane finished specimen in order to obtain A_1 , according to Equation 2. Fig. 3 indicates that Equation 2 can be applied to calculating fracture toughness, because the fit of the data to the straight line is excellent. Fig. 3 is representative of all specimens for this condition.

2.4. Fracture toughness of vinyl ester resin mixed with methacryl silane

The fracture toughness of the vinyl ester resin mixed with methacryl silane was measured by using a compact specimen (ASTM E 399-83).

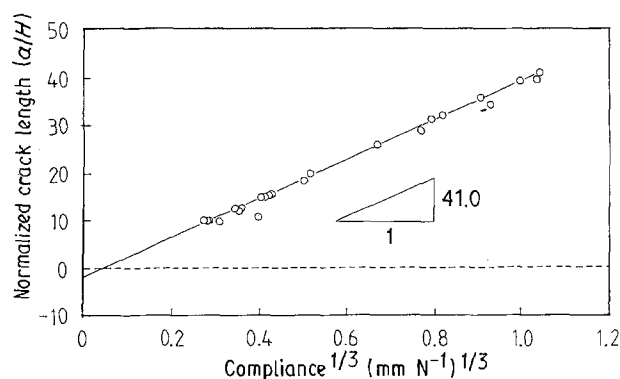

Figure 3 Experimental relation between cube root of compliance and normalized crack length of the DCB specimens for 0.4 wt % epoxy silane.

TABLE I Mechanical properties of 0.4 wt % epoxy silane and 0.01, 0.4, 1.0 wt % methacryl silane finished specimens

	Epoxy silane	Methacryl silane		
	0.4 wt %	0.01 wt %	0.4 wt %	1.0 wt %
Tensile strength (MPa)	361	341	373	371
Young's modulus (GPa)	21.7	23.4	22.4	22.1
Flexural strength (MPa)	421	447	447	460
Interlaminar shear strength (MPa)	29.6	39.4	39.4	47.8

2.5. Tensile, flexural and interlaminar shear strength

The GFFLs were cut and tested in tensile, flexural and interlaminar shear in accordance with ASTM Standards D-3039, D-790 and D-2344, respectively.

3. Results

3.1. Tensile and flexural test of GFFL

The results of tensile and flexural strength tests are summarized in Table I. The results of the tensile strength data indicate that 0.01 wt % methacryl silane finished specimen is the weakest. The specimens finished with 0.4 and 1.0 wt % methacryl silane have approximately the same tensile strength. The Young's moduli of four specimens in Table I also show nearly the same values. Table I indicates that the value of flexural strength and interlaminar shear strength of the 0.4 wt % epoxy silane finished specimen is the lowest. Both the 0.4 and 1.0 wt % methacryl silane

finished specimens show the strongest tensile, flexural and shear test data.

3.2. Fracture toughness test

Fig. 4a–d show the load–displacement curves for four different silane finished specimens. The value of load decreased slowly in Fig. 4a and b. On the other hand, the value of load dropped drastically and decreased slowly in the same load–displacement curve in Fig. 4c and d, in proportion to the increase of methacryl silane concentration. These load–displacement curves can be divided into two patterns, in terms of crack propagation behaviour: the first is a stable crack propagating growth pattern, the second is an unstable crack propagating growth pattern [3]. The stable crack propagation, shown in Fig. 4a and b, grew slowly during the crack propagation. During measurements of the crack propagation in 0.4 and 1.0 wt % methacryl silane finished specimens, the crack started

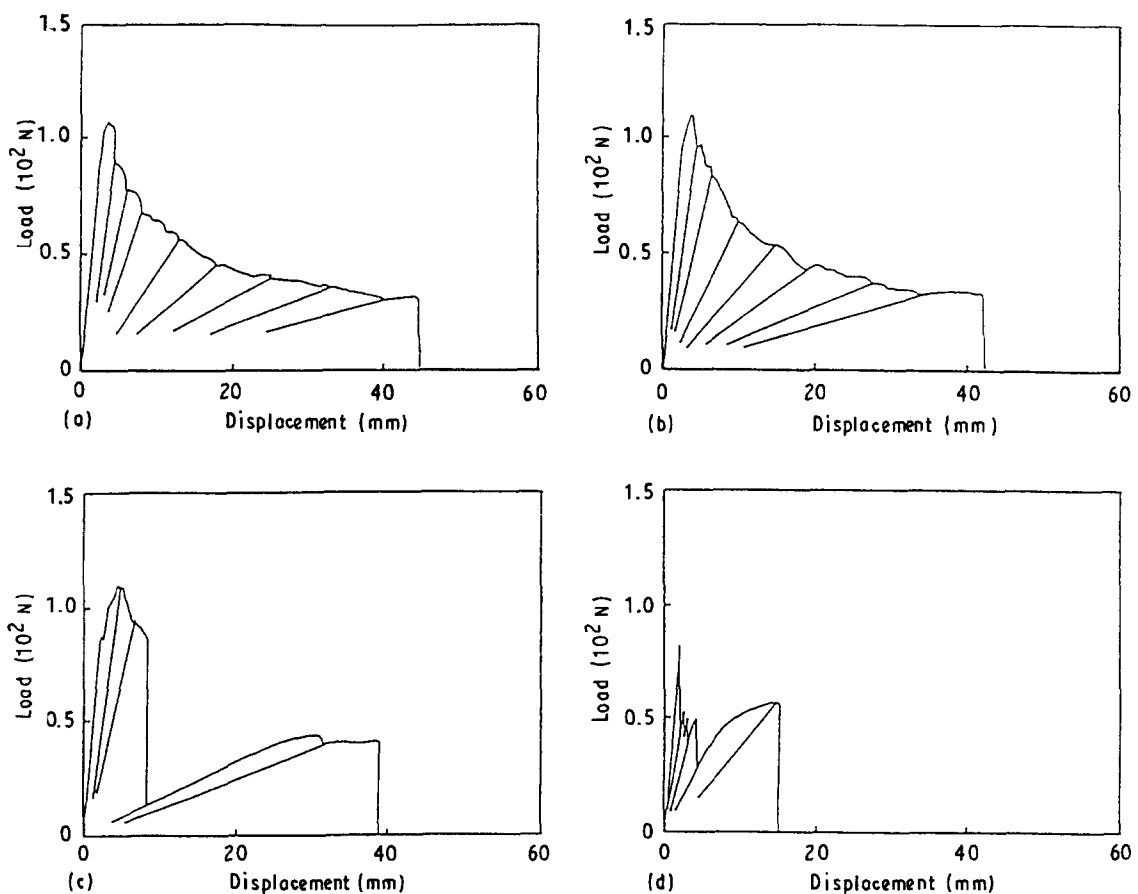

Figure 4 Load–displacement curves for (a) 0.4 wt % epoxy silane, (b) 0.01 wt % methacryl silane, (c) 0.4 wt % methacryl silane and (d) 1.0 wt % methacryl silane finished GFFLs.

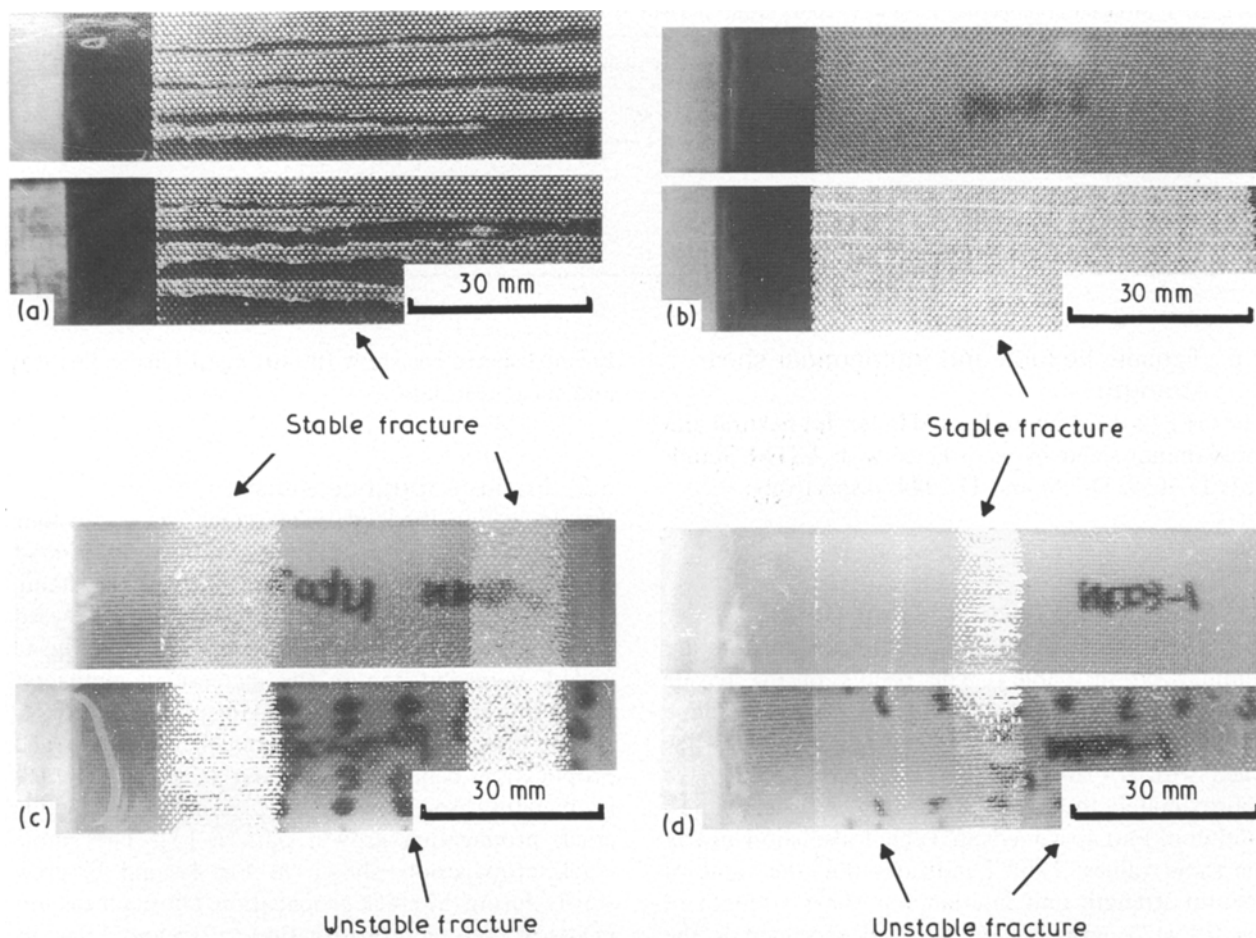

Figure 5 Macroscopic observation of the fracture surface of (a) 0.4 wt% epoxy silane, (b) 0.01 wt% methacryl silane, (c) 0.4 wt% methacryl silane and (d) 1.0 wt% methacryl silane.

to grow slowly from a starter defect (initiation) and in a couple of cases kept growing slowly (stable crack propagation). An unstable crack suddenly occurred quickly in the specimens finished with 0.4 and 1.0 wt% methacryl silane and both the stable and unstable crack propagation were seen in the same specimen. The specimen finished with 1.0 wt% methacryl silane was split at less than 20 mm displacement distance. Unstable propagation was easy in 1.0 wt% methacryl silane finished specimen.

3.3. Macroscopic and microscopic observation of fracture surfaces

Fig. 5a–d show the macroscopic photographs of the fracture surfaces of four specimens. The light region corresponds to the stable crack propagation. The dark region corresponds to the unstable crack propagation. Because the crack propagated across the glass fibre fabric, the stable slight fracture surface on both sides of the epoxy silane finished specimen of Fig. 5a looks like several ribbons running in the crack direction. Fig. 5a and b show photographs of the fracture surfaces of the 0.4 wt% epoxy silane and the 0.01 wt% methacryl silane finished specimen respectively. The upper picture of Fig. 5b illustrates the fracture surface covered with vinylester resin. However, the lower picture of Fig. 5b reveals glass fibre fabric. Stable and unstable crack propagation are seen in the same specimen for both 0.4 and 1.0 wt% methacryl silane finish-

ed specimens, respectively. The white glass fibre strand area in methacryl silane 1.0 wt% finished specimen is smaller than that of the 0.4 wt% methacryl silane finished specimen. Thus unstable crack propagation in the 1.0 wt% methacryl silane finished specimen possibly occurred more than in the 0.4 wt% methacryl silane finished specimen.

Fig. 6a and b show the scanning electron micrographs of fracture surfaces for DCB specimens. Fig. 6a shows the stable crack growth of the 0.4 wt% epoxy silane finished specimen. This figure shows the exposed glass fibre strands without resin. Fig. 6b shows the unstable crack growth of the 0.4 wt% methacryl silane finished specimen. The fracture surface is mainly covered with resin and only weft glass fibre strands were seen on the fracture surface. It can be concluded that the stable crack propagates through the interphase of the glass fibre/resin and the unstable crack propagates through the resin between the glass fibre fabrics.

Fig. 7a and b show scanning electron micrographs of the fracture surfaces of stable crack propagation for the 0.4 wt% epoxy silane and methacryl silane finished specimens, respectively. In Fig. 7a there is no vinylester resin around the glass fibres and the interphase of the 0.4 wt% epoxy silane finished specimen is very poor. In Fig. 7b there is cohesive failure around the glass fibres on the fracture surface. The specimen finished with 0.4 wt% methacryl silane has a good adhesive interphase.

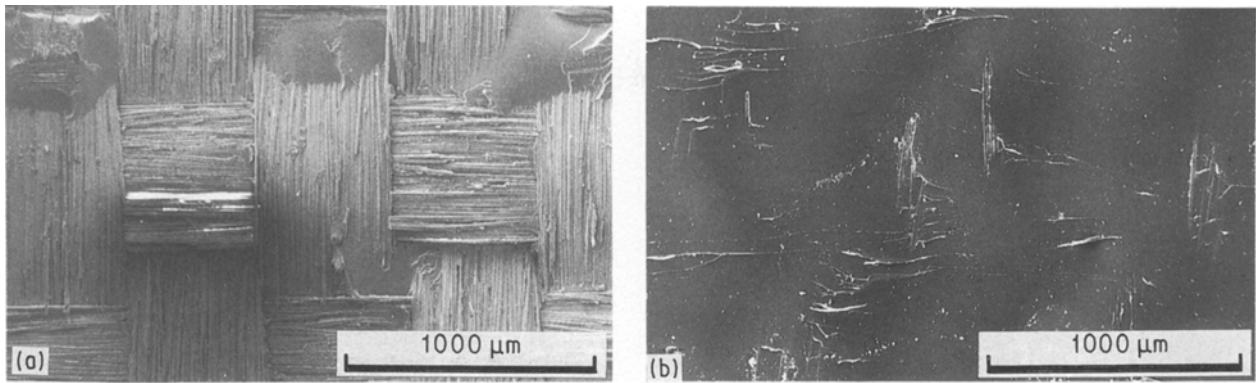

Figure 6. Scanning electron micrographs of the DCB specimen fracture surfaces: (a) stable crack growth of 0.4 wt % epoxy silane finished specimen, and (b) unstable crack growth of 0.4 wt % methacryl silane finished specimen.

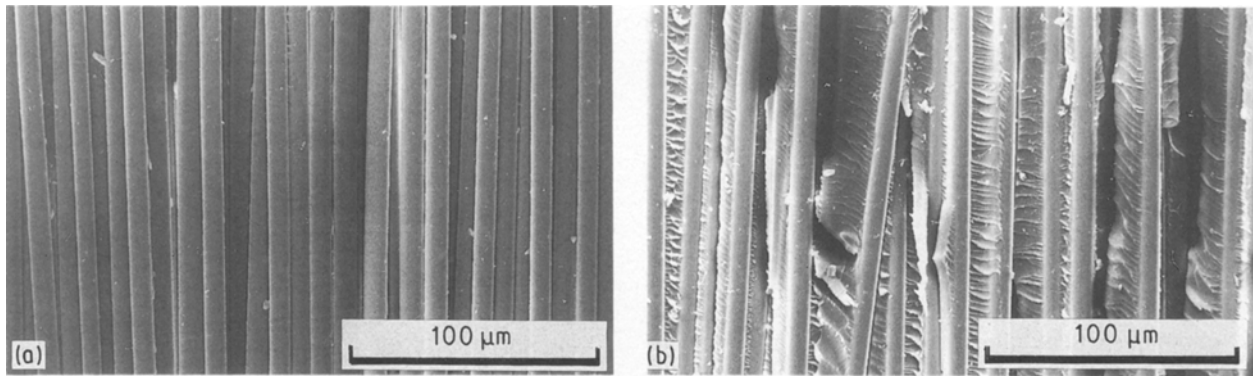

Figure 7 Scanning electron micrographs of the DCB specimen fracture surfaces: (a) stable crack growth of 0.4 wt % epoxy silane finished specimen, and (b) stable crack growth of 0.4 wt % methacryl silane finished specimen.

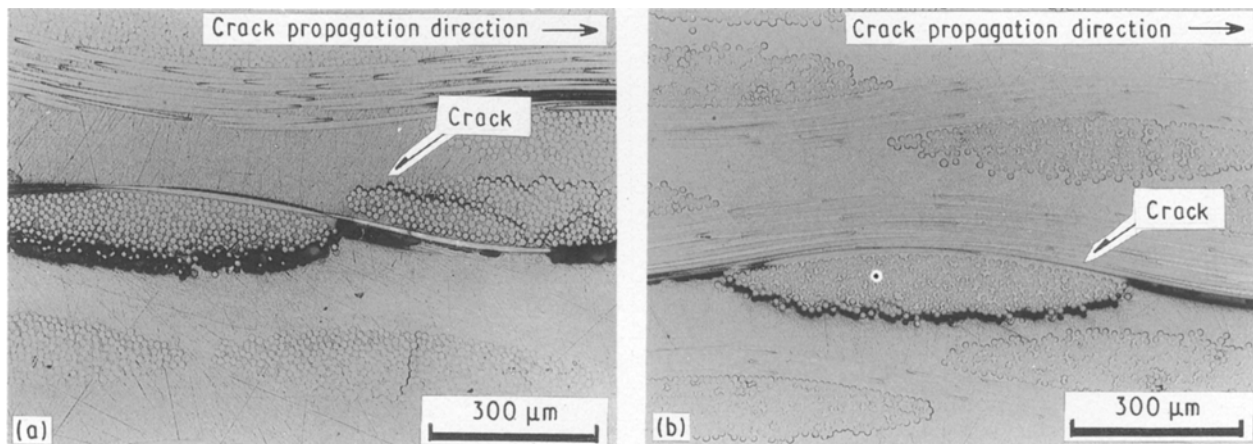

Figure 8 Micrographs of the DCB specimen crack propagation: (a) stable crack growth of 0.4 wt % epoxy silane finished specimen, and (b) stable crack growth of 0.4 wt % methacryl silane finished specimen.

Fig. 8a and b show micrographs of the stable crack growth of a 0.4 wt % epoxy and methacryl silane finished specimen respectively. The interphase of the 0.4 wt % epoxy silane finished specimen is so poor that cracking occurred within glass fibre strands when the main crack passed. On the other hand, in Fig. 8b, no cracking occurred inside glass fibre strands when the main crack passed.

The fracture surface roughness was measured in order

to investigate the difference between the stable and unstable cracks. The results from the stable and unstable maximum fracture surface roughness measurements are shown in Fig. 9. The maximum surface roughness data of the stable fracture are higher than those of the unstable one, because the crack in the unstable region grew through vinylester resin between the fabrics in GFFL. These results agree well with the macroscopic and microscopic observations mentioned above.

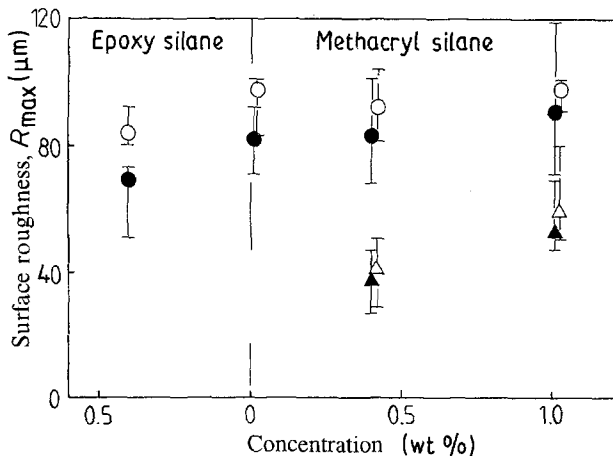

Figure 9 (\circ , \bullet) Stable and (\triangle , \blacktriangle) unstable fracture surface roughness of four surface-finished GFFLs. (\circ , \triangle) Warp, (\bullet , \blacktriangle) weft.

The stable crack propagated along the interphase of glass fibre/resin. On the other hand, the unstable crack propagated in the resin between the glass fibre fabrics.

3.4. Relation between fracture toughness and crack length

Fig. 10a–d illustrate the relation between fracture toughness, G_i , and the crack length for four types of surface finished specimens, and correspond to the load–displacement curves in Fig. 4a–d. Fig. 10a and b show that the fracture toughness of the stable crack propagation is approximately constant. On the other hand, Fig. 10c and d indicate a high fracture toughness. The unstable crack gives low values of fracture

toughness and the stable crack gives high values, corresponding to the pictures in Fig. 5. Thus the result shows that the range of fracture toughness is wide.

3.5. Fracture toughness of vinylester resin mixed with methacryl silane

Fig. 11 illustrates the relation between the fracture toughness, K_{Ic} , and the amount of methacryl silane mixed with the vinylester resin. The value of K_{Ic} decreases in proportion to the increase in methacryl silane content in the vinylester resin.

4. Discussion

4.1. Fracture toughness

The crack propagation behaviour can be divided into three categories as shown in Fig. 12: (1) initiation; (2) stable crack propagation; (3) unstable crack propagation. The mean values of five specimens in each category for four types of specimens are plotted in Fig. 13.

4.1.1. Initiation of crack propagation

Fracture toughness of methacryl silane finished GFFL decreases in proportion to the methacryl silane concentration. Because the adhesive property of glass fibre/vinylester resin interphase with 0.01 wt % methacryl silane finished GFFL is insufficient, the crack began to grow from the space between the PTFE film/resin and the crack propagated along the glass fibre/resin interphase. Fracture energy was dispersed

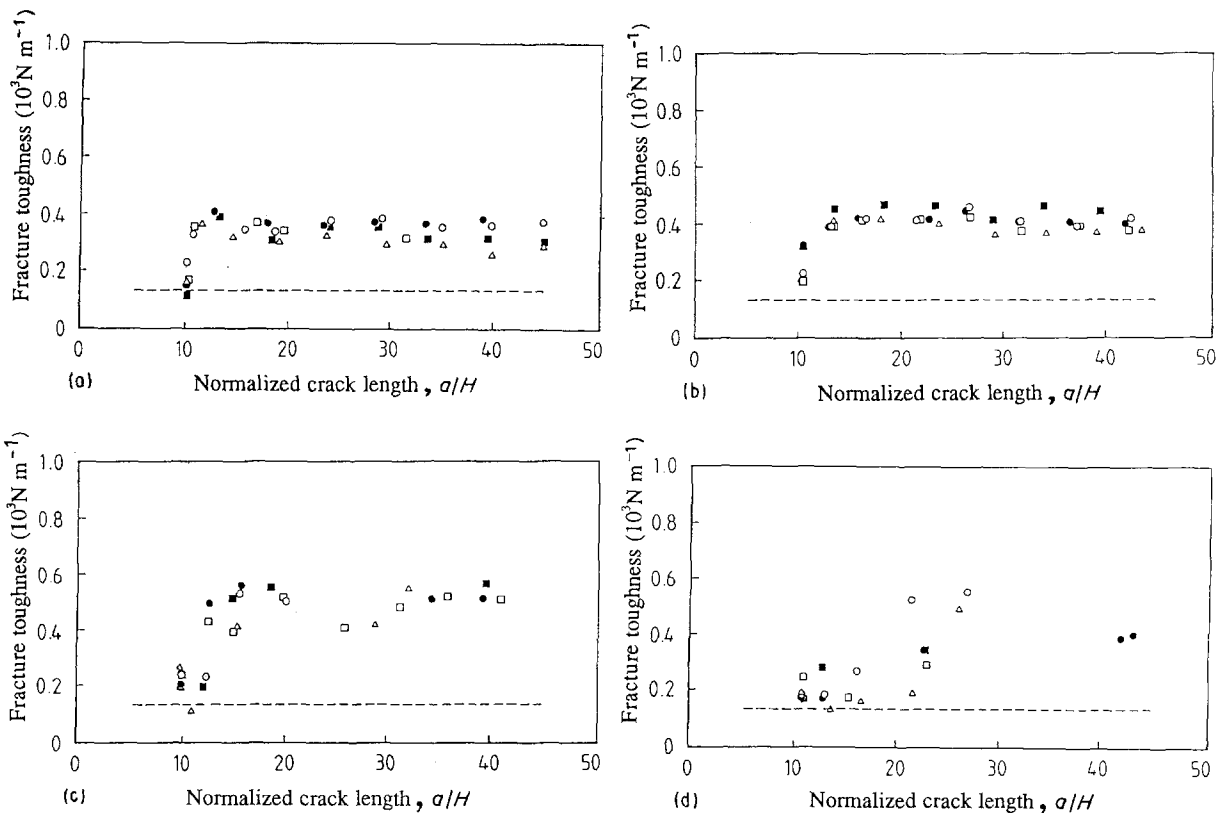

Figure 10 Relation between fracture toughness, G_{Ic} and crack propagating length for (a) 0.4 wt % epoxy silane, (b) 0.01 wt % methacryl silane, (c) 0.4 wt % methacryl silane and (d) 1.0 wt % methacryl silane finished GFFLs. (---) Resin.

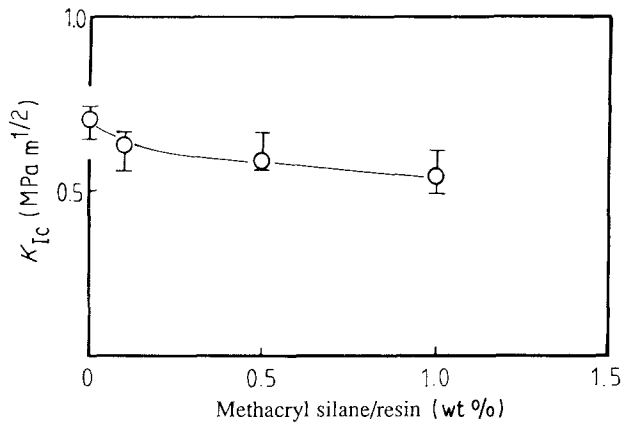

Figure 11 K_{Ic} of the vinylester resin mixed with three concentrations of methacryl silane.

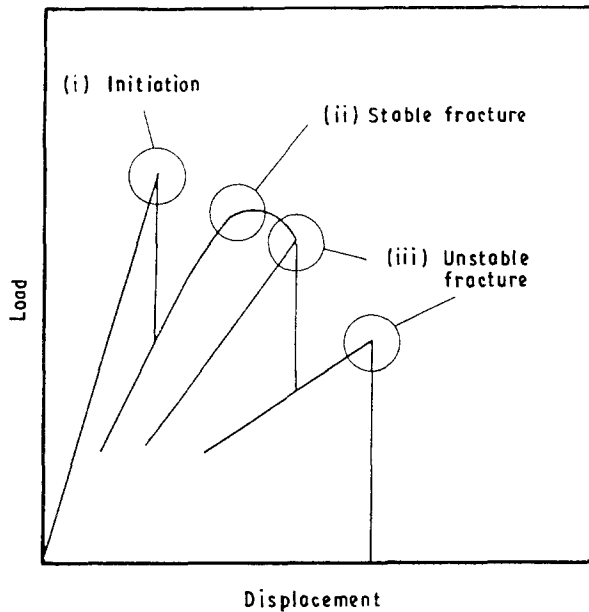

Figure 12 Schematic drawing of the crack growth pattern on load-displacement response.

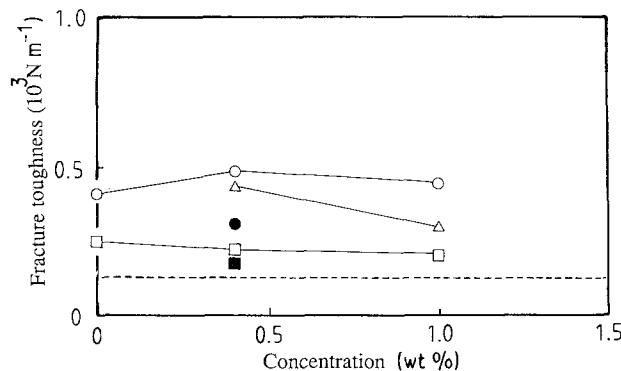

Figure 13 Fracture toughness of four surface finished GFFLs in relation to the crack propagation pattern. Methacryl silane: (○) stable fracture, (△) unstable fracture, (□) initiation; epoxy silane: (●) stable fracture, (■) initiation; (---) Resin.

through this poor adhesive 0.01 wt % methacryl silane finished glass fibre/resin interphase. Thus a higher initial toughness with 0.01 wt % methacryl silane finished GFFL was obtained. For the case of the 0.4 and 1.0 wt % methacryl silane finished glass fibre fabrics,

the crack originated in the space between the PTFE film/resin and propagated into the resin-rich region between the glass fibre fabrics, because the bond at the interphase was strong. The fracture toughness of these two finish concentrations was close to that of the polymerized vinylester resin.

4.1.2. Stable crack propagation

The 0.4 wt % methacryl silane finished specimen shows the highest fracture toughness in Fig. 13.

4.1.3. Unstable crack propagation

The fracture toughness decreased in proportion to the increase in concentration of the methacryl silane aqueous solution. The 0.4 wt % epoxy silane finished specimen has the lowest value of all four specimens in the initiation and stable fracture, because epoxy silane has no organic function which can react with vinylester resin.

4.2. Effect of silanes and their concentrations on delamination fracture toughness

The unstable fracture phenomenon indicates that the excessive amount of methacryl silane may cause unstable crack propagation around the glass fibre. Methacryl silane, which has a double bond chemical function, is a good adhesive agent for glass fibre/vinylester resin laminate, because there is cohesive failure around glass fibre strands on the fracture surface shown in Fig. 7b. Methacryl silane cross-linked the polyester resin, so that the methacryl silane/unsaturated polyester blend became brittle and there was a slight increase in the modulus as siloxane [5]. Methacryl silane hardens the vinylester resin; thus the fracture toughness decreases in proportion to the amount of methacryl silane mixed with the vinylester resin, as shown in Fig. 11. As the interphase between glass and vinylester resin in 1.0 wt % methacryl silane finished GFFL is too strong, the crack grows easily into the resin-rich region. In the case of unstable fracture toughness, the unstable fracture toughness decreases in proportion to the incremental concentration of the methacryl silane aqueous solution, as seen in Fig. 13. The interlaminar fracture toughness is very much dependent on silane type (organic function of silane) and its concentration. Moreover, the optimum silane amount on the glass fibre should be achieved in order to increase the delamination resistance of GFFL.

5. Conclusions

1. A fracture toughness test using a DCB specimen provides a sensitive analytical technique by which to evaluate the very slight surface finish difference on the glass fibre fabric laminate.

2. Interlaminar fracture toughness of GFFL is influenced by silane type and silane solution concentration. There is an optimum amount of silane on the glass fibre which is required to accomplish the max-

imum fracture toughness. Reduction of the fracture toughness of GFFL was observed with an excessive amount of silane.

3. An excessive amount of methacryl silane on glass fibres causes polymerization with a high cross-linkage for vinylester resin, and causes unstable crack propagation.

References

1. E. P. PLUEDDEMANN, SPI 39th Annual Conference, 4-C (1984).

2. D. J. VAUGHAN and R. C. PEEK Jr, "Adhesion Aspects of Polymeric Coatings" (Elsevier, New York, 1983) p. 409.
3. R. A. CRICK, D. C. LEACH, P. J. MEAKIN and D. R. MOORE, *J. Mater. Sci.* **22** (1987) 2094.
4. K. KAGEYAMA and M. HOJO, in "Proceedings of the 5th Japan-US Conference on Composite Materials", 1990 (Kokon-Shoin, Japan, 1990).
5. R. T. GRAF, J. L. KOENIG and H. ISHIDA, *J. Adhesion* **16** (1983) 97.

*Received 11 June
and accepted 31 October 1991*